

the 
manual

RHINO FILTER REGULATOR LUBRICATOR

Part No. 601128

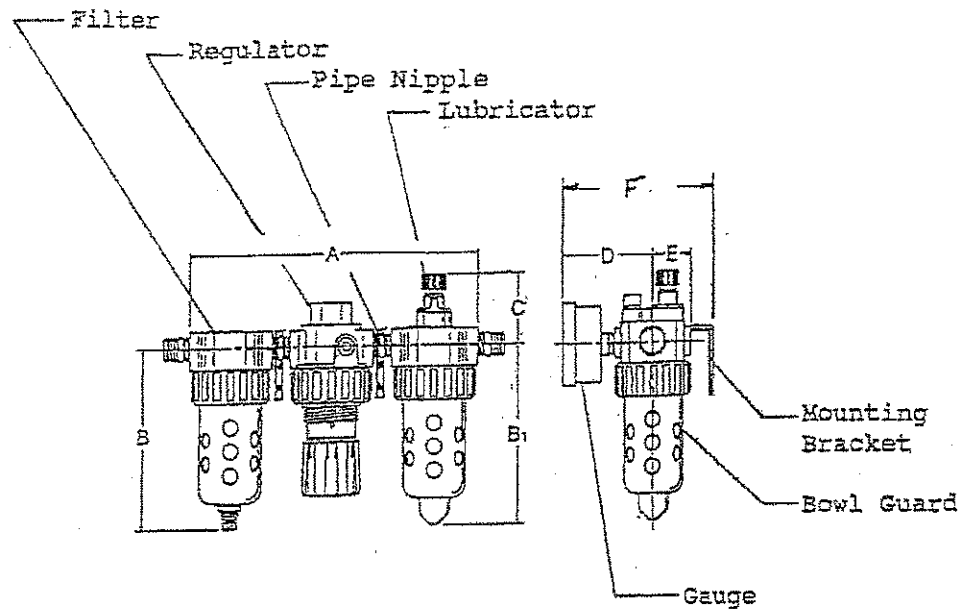

GENERAL DIMENSIONS

"A"	=	10.7"
"B"	=	7.0"
"B1"	=	6.9"
"C"	=	2.2"
"D"	=	3.4"
"E"	=	1.6"
"F"	=	5.2"

ITEM	PORT OR THREAD SIZE	QUANTITY	PART #
Filter	3/4" NPT	1	601129
Regulator	3/4" NPT	1	601130
Lubricator	3/4" NPT	1	601131
Gauge	1/4" NPT	1	601104
Pipe Plug (not shown)	1/4" NPT	1	601115
Pipe Nipple (Close)	3/4" NPT	2	230401
Mounting Bracket		2	70574
Mounting U-Bolts (not shown)		2	500020
Bowl Guard (Metal)		2	601134

FILTER REGULATOR LUBRICATOR

(referred to in text as FRL)

INSTALLATION

1. The equipment to which the FRL is attached should be internally cleaned to remove all traces of accumulated oil and dirt.
2. New pipe or hoses should be installed between your new Rhino FRL and the equipment being protected.
3. Blow all upstream hoses and pipe work clear of accumulated dirt and liquids.
4. Locate your FRL as close as possible to your post driver. (25' or closer is recommended)
5. Install your FRL in a vertical position (drain on the filter towards the bottom). The air flows in the direction of the arrows.
6. Install the mounting bracket to the air regulator as shown in Fig. 1. If you are using your FRL with a Rhino carrier, refer to Fig. 2. (The carrier is optional and not part of the FRL.)

MISCELLANEOUS INFORMATION

1. See the following pages for parts kits and detailed information on each component part of your Rhino FRL.
2. Air gauges are not serviced. If replacement is required, order the complete gauge. (Part No. 601104)
3. With proper care and maintenance, your Rhino FRL will provide many hours of trouble free service while protecting and lubricating your air tools.

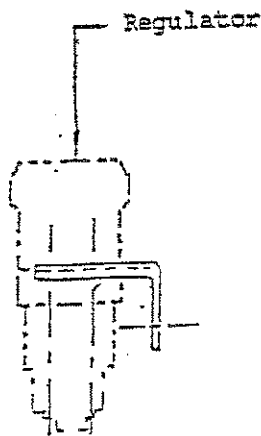

Fig. 1

U-Bolts Not Shown

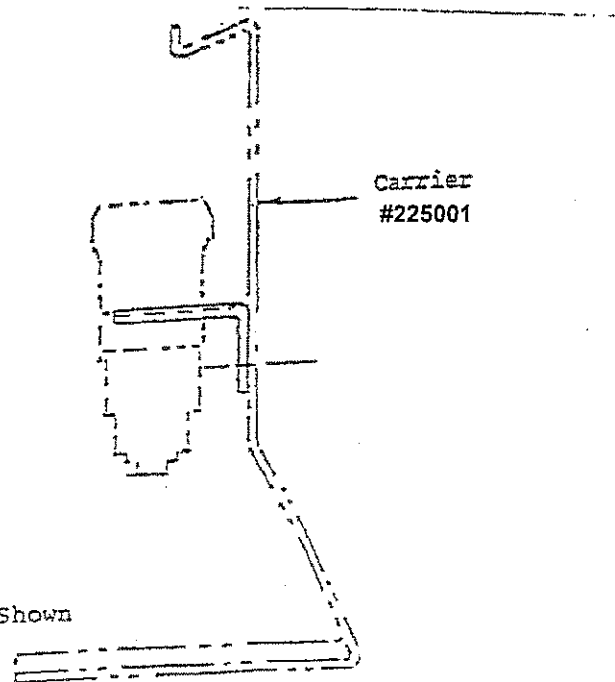
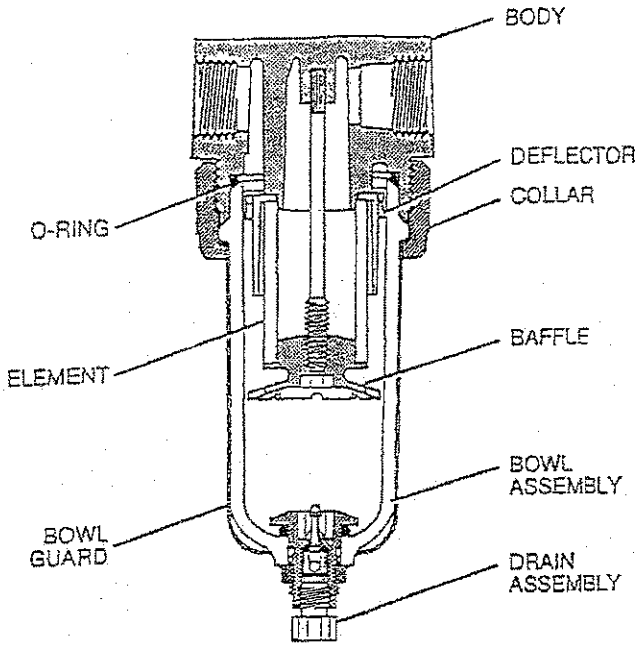

Fig. 2

CROWDER SUPPLY CO., INC. - 8495 ROSLYN ST. - COMMERCE CITY, CO 80022 - TOLL FREE 888-883-5144 - www.crowdersupply.com



Installation

1. The filter should be installed with reasonable accessibility for service whenever possible - repair service kits are available. Keep pipe or tubing lengths to a minimum with inside clean and free of dirt and chips. Pipe joint compound should be used sparingly and applied only to the male pipe - never into the female port. Do not use Teflon[®] tape to seal pipe joints - pieces have a tendency to break off and lodge inside the unit, possibly causing malfunction. Also, new pipe or hose should be installed between the filter and equipment being protected.
2. The upstream pipe work must be clear of accumulated dirt and liquids.
3. Select a filter location as close as possible to the equipment being protected and upstream of any pressure regulator.
4. Install filter so that air flows in the direction of arrow on body.
5. Install filter vertically with bowl drain mechanism at the bottom. Free moisture will thus drain into the sump ("quiet zone") at the bottom of the bowl.

Application Limits

These products are intended for use in general purpose compressed air systems only.

Adsorber Filters are not effective on: Carbon monoxide, carbon dioxide, methane, ethane, ethylene or hydrogen. For a complete list of vapors that can and cannot be adsorbed effectively by activated charcoal adsorbers consult the factory.

! WARNING

To avoid unpredictable system behavior that can cause personal injury and property damage:

- Disconnect air supply and depressurize all air lines connected to this product before installation, servicing, or conversion.
- Operate within the manufacturer's specified pressure, temperature, and other conditions listed on these instructions.
- Medium must be moisture-free if ambient temperature is below freezing.
- Service according to procedures listed in these instructions.
- Installation, service, and conversion of these products must be performed by knowledgeable personnel who understand how pneumatic products are to be applied.
- After installation, servicing, or conversion, air supply should be connected and the product tested for proper function and leakage. If audible leakage is present, or the product does not operate properly, do not put into use.
- Warnings and specifications on the product should not be covered by paint, etc. If masking is not possible, contact your local representative for replacement labels.

Maximum Recommended Pressure Drop:

	psig	bar	kPa
Particulate Filter	10	0.7	70
Adsorber Filter	1.5	0.1	10

With Polycarbonate Bowl

	psig	bar	kPa
Operating Pressure Maximum	150	10.3	1000
Operating Temperature Maximum	+125°F (+52°C)		
Operating Temperature Minimum	+32°F (0°C)		

With Metal Bowl

	psig	bar	kPa
Operating Pressure Maximum	250	17.0	1700
Operating Temperature Maximum	+175°F (+80°C)		
Operating Temperature Minimum	+32°F (0°C)		

ANSI Symbols

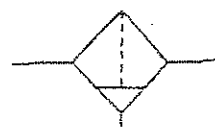

Filter w/Manual Drain

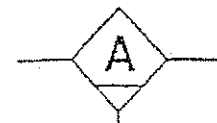

Adsorber w/Manual Drain

FILTER OPERATION AND SERVICE

1. Both free moisture and solids are removed automatically by the filter. There are no moving parts.
2. Manual drain filters must be drained regularly before the separated moisture and oil reaches the bottom of the lower baffle.
3. The particulate filter element should be removed and replaced when pressure differential across the filter is 10 PSIG.
4. To replace the filter element:
 - A. Shut off air supply and depressurize the unit.
 - B. Unscrew the threaded collar and remove bowl.
 - C. Unscrew the lower baffle and remove filter element.
 - D. Clean all internal parts and bowl before reassembling. See polycarbonate bowl cleaning section below.
 - E. Install element.
 - F. Attach lower baffle and tighten firmly
 - G. Replace bowl seal; lubricate seal to assist in retaining it in position. Use only mineral base oils or grease. Do not use synthetic oils such as esters and do not use silicones.
 - H. Install bowl into body and tighten standard collar to 48 - 32 inch pounds torque.

<u>MAINTENANCE SERVICE KIT</u>	<u>STD. RHINO PART NO.</u>
<u>Element Kits (element kits include body/bowl seal)</u>	
<u>- 5 Micron</u>	<u>601137</u>
<u>- 40 Micron</u>	<u>601136</u>

SAFETY: Polycarbonate Bowls

CAUTION: Polycarbonate bowls, being transparent and tough, are ideal for use with Filters and Lubricators. They are suitable for use in normal industrial environments, but should not be located in areas where they could be subjected to direct sunlight, an impact blow, nor temperatures outside of the rated range. As with most plastics, some chemicals can cause damage. Polycarbonate bowls should not be exposed to chlorinated hydrocarbons, ketones, esters and certain alcohols. They should not be used in air systems where compressors are lubricated with fire-resistant fluids such as phosphate ester and di-ester types.

Metal bowls are recommended where ambient and/or media conditions are not compatible with polycarbonate bowls. Metal bowls resist the action of most such solvents, but should not be used where strong acids or bases are present or in salt laden atmospheres. Consult the factory for specific recommendations where these conditions exist.

TO CLEAN POLYCARBONATE BOWLS USE MILD SOAP AND WATER ONLY! DO NOT use cleansing agents such as acetone, benzene, carbon tetrachloride, gasoline, toluene, etc., which are damaging to this plastic.

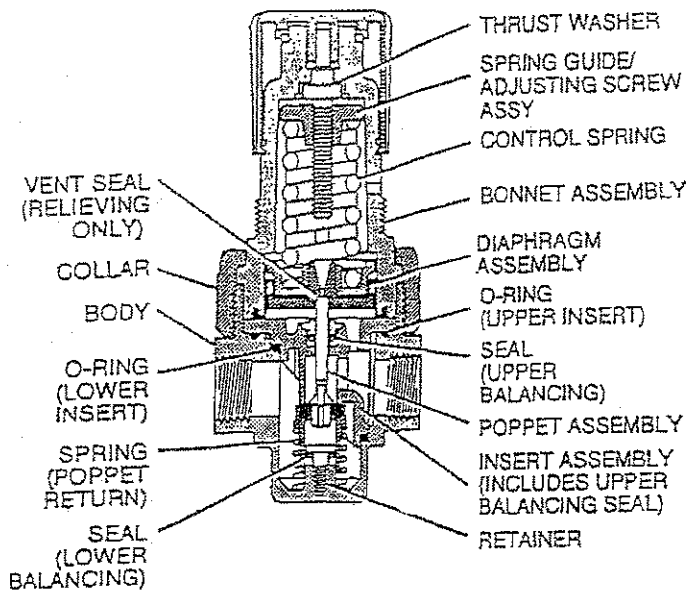

Installation

1. The regulator should be installed with reasonable accessibility for service whenever possible – repair service kits are available. Keep pipe or tubing lengths to a minimum with inside clean and free of dirt and chips. Pipe joint compound should be used sparingly and applied only to the male pipe – never into the female port. Do not use Teflon[®] tape to seal pipe joints – pieces have a tendency to break off and lodge inside the unit, possibly causing malfunction.
2. Install regulator so that air flow is in the direction of arrow. Installation must be upstream from devices it is to service (lubricator, valve, cylinder or tool), and mounted closely to these devices. Mounting may be in any position.
3. Gauge ports are located on both sides of the regulator body for your convenience. It is necessary to install a gauge or socket pipe plug into each port during installation.
4. For protection against rust, pipe scale and other foreign matter, install a filter on the upstream (high pressure) side as closely to the regulator as possible.

Application Limits

These products are intended for use in general purpose compressed air systems only.

Operating Pressure:	psig	bar	kPa
Maximum Inlet Pressure	250	17	1700

Operating Temperature:	
Maximum Temperature	+175°F (+80°C)
Minimum Temperature	+32°F (0°C)

ANSI Symbols

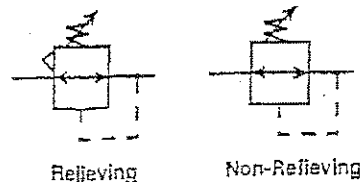

WARNING

To avoid unpredictable system behavior that can cause personal injury and property damage:

- Disconnect air supply and depressurize all air lines connected to this product before installation, servicing, or conversion.
- Operate within the manufacturer's specified pressure, temperature, and other conditions listed on these instructions.
- Medium must be moisture-free if ambient temperature is below freezing.
- Service according to procedures listed in these instructions.
- Installation, service, and conversion of these products must be performed by knowledgeable personnel who understand how pneumatic products are to be applied.
- After installation, servicing, or conversion, air supply should be connected and the product tested for proper function and leakage. If audible leakage is present, or the product does not operate properly, do not put into use.
- Warnings and specifications on the product should not be covered by paint, etc. If masking is not possible, contact your local representative for replacement labels.

REGULATOR OPERATING AND SERVICE

1. Before turning on the air supply, turn the adjusting knob counterclockwise until compression is released from the pressure control spring, then turn on air supply. Proceed to adjust the desired downstream pressure by turning adjusting knob clockwise. This permits pressure to build up slowly in the downstream line.
2. To decrease regulated pressure setting, always reset from a pressure lower than the final setting required. Example, lowering the secondary pressure from 80 PSIG to 60 PSIG is best accomplished by dropping the secondary pressure to 50 PSIG, then adjusting upward to 60 PSIG.
3. When desired secondary pressure setting has been reached, push the adjusting knob down to lock the adjusting knob.
4. To service the regulator diaphragm, poppet assembly and seat insert:
 - A. Shut off the air supply and depressurize the unit.
 - B. Disengage the adjusting knob by pulling upward.
Turn adjusting knob counterclockwise until the compression is released from the pressure control spring. Turning the knob counterclockwise does not vent downstream pressure on non-relieving regulators. Downstream pressure must be vented before servicing regulator.
 - C. Unscrew the threaded collar and remove the bonnet assembly.
 - D. Disassemble, clean and carefully inspect parts for wear or damage. If replacement is necessary, use parts from the service kits.
 - E. Lubricate o-ring and vee packing seals with grease found in the kit
 - F. Install poppet return spring, poppet assembly, upper and lower seat insert o-rings and seat insert.
 - G. Install diaphragm assembly into bonnet.
 - H. Assemble bonnet to body and tighten threaded collar hand tight plus 1/4 turn.
5. Turn on air pressure and check regulator for leakage. If leakage occurs, DO NOT OPERATE - Conduct repairs again.

<u>MAINTENANCE SERVICE KITS</u>	<u>STANDARD 3/4"</u>
<u>Relieving Regulator Repair Kit</u>	<u>601138</u>
<u>Seat Insert Repair Kit</u>	<u>601140</u>

<u>ADDITIONAL ACCESSORIES</u>	<u>KIT NUMBER</u>
<u>Gauges - 0 to 160 PSI (Standard)</u>	<u>601104</u>
<u>Mounting Bracket Kit (Standard)</u>	<u>70574</u>
<u>Air Pilot Conversion (Relieving)</u>	<u>601138</u>
<u>Bonnet Assembly</u>	<u>601139</u>

WARNING

FAILURE OR IMPROPER SELECTION OR IMPROPER USE OF THE PRODUCTS AND/OR SYSTEMS DESCRIBED HEREIN OR RELATED ITEMS CAN CAUSE DEATH, PERSONAL INJURY AND PROPERTY DAMAGE.

This document and other information from The Company, its subsidiaries and authorized distributors provide product and/or system options for further investigation by users having technical expertise. It is important that you analyze all aspects of your application, including consequences of any failure and review the information concerning the product or system in the current product catalog. Due to the variety of operating conditions and applications for these products or systems, the user, through its own analysis and testing, is solely responsible for making the final selection of the products and systems and assuring that all performance, safety and warning requirements of the application are met.

The products described herein, including without limitation, product features, specifications, designs, availability and pricing, are subject to change by The Company and its subsidiaries at any time without notice.

CROWDER SUPPLY CO., INC. - 8495 ROSLYN ST. - COMMERCE CITY, CO 80022 - TOLL FREE 888-883-5144 - www.crowdersupply.com

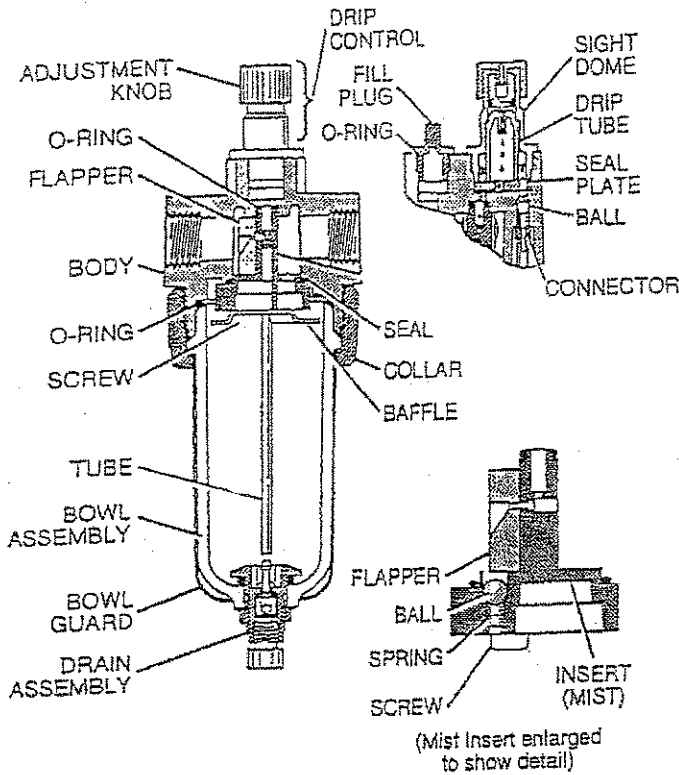

Micromist Shown

WARNING

To avoid unpredictable system behavior that can cause personal injury and property damage:

- Disconnect air supply and depressurize all air lines connected to this product before installation, servicing, or conversion.
- Operate within the manufacturer's specified pressure, temperature, and other conditions listed on these instructions.
- Medium must be moisture-free if ambient temperature is below freezing.
- Service according to procedures listed in these instructions.
- Installation, service, and conversion of these products must be performed by knowledgeable personnel who understand how pneumatic products are to be applied.
- After installation, servicing, or conversion, air supply should be connected and the product tested for proper function and leakage. If audible leakage is present, or the product does not operate properly, do not put into use.
- Warnings and specifications on the product should not be covered by paint, etc. If masking is not possible, contact your local representative for replacement labels.

Installation

1. The lubricator should be installed with reasonable accessibility for service whenever possible - repair service kits are available. Keep pipe or tubing lengths to a minimum with inside clean and free of dirt and chips. Pipe joint compound should be used sparingly and applied only to the male pipe - never into the female port. Do not use Teflon[®] tape to seal pipe joints - pieces have a tendency to break off and lodge inside the unit, possibly causing malfunction.
2. Install lubricator so air flows in the direction of arrow on body.
3. Installation should be upstream of the device it is to lubricate (valve, cylinders, tool, etc.).

Application Limits

These products are intended for use in general purpose compressed air systems only.

With Polycarbonate Bowl

	psig	bar	kPa
Operating Pressure Maximum	150	10.3	1000
Operating Temperature Maximum	+125°F (+52°C)		
Operating Temperature Minimum	+32°F (0°C)		

With Metal Bowl

	psig	bar	kPa
Operating Pressure Maximum	250	17.0	1700
Operating Temperature Maximum	+175°F (+80°C)		
Operating Temperature Minimum	+32°F (0°C)		

ANSI Symbol

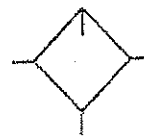

LUBRICATOR OPERATION AND SERVICE

1. Filling - The Mist lubricator can be filled without turning off the upstream pressure. Slowly remove the fill plug (black) by turning counterclockwise. This allows the bowl pressure to vent.

Suggested lubricant: SAE 5 wt. for cold weather (in very cold conditions you may want to dilute your SAE 5 wt. to provide proper lubrication), SAE 10 wt. for mild weather to 80 degrees, and SAE 20 wt. for hot weather. Do not use oils with adhesives, compound oils containing solvents, graphite, detergents or synthetic oils.

2. Replace the fill plug (by turning clockwise) and seat firmly. Excessive torque is not required
3. Oil delivery adjustment - To adjust oil delivery, turn adjustment knob on top of lubricator

Leaner - clockwise

Richer - Counterclockwise

By counting the number of drops per minute in the sight dome, you can adjust to your requirements.

Mist lubricator - Every drop visible in the sight dome goes downstream. Generally, one drop per minute downstream for every 10 - 15 SCFM flow is satisfactory.

25 drops per minute equals one (1) ounce per hour - volume of oil passing through the sight dome.

NOTE: This is a constant density type lubricator which delivers a constant ratio of oil air flow. Therefore, if air flow increases or decreases, oil delivery will be adjusted proportionately. **ONLY IF A DIFFERENT RATIO IS DESIRED SHOULD YOUR ADJUSTMENT KNOB SETTING BE CHANGED AFTER YOUR INITIAL SETTING.**

4. To replace fill plug:
 - A. Turn off air supply and depressurize the unit.
 - B. Unscrew fill plug and clean sealing surfaces on lubricator body.
 - C. Lubricate the o-ring seal on replacement part with grease included in the kit. Assemble o-ring to fill plug. Install the fill plug and tighten hand tight.
 - D. Turn on air supply and check for leakage. If leaks occur, repeat repair procedure.
5. To replace drip control: (see cutaway view)
 - A. Turn off air supply and depressurize the unit.
 - B. Unscrew drip control by rotating sight dome counterclockwise. Carefully remove seal plate. Note: Do not damage surface of body underneath seal plate.
 - C. Lubricate seal plate with grease found in the kit. Align and install seal plate.
 - D. Install sight dome and drip tube. Tighten to 10 - 15 inch pounds of torque.
 - E. Turn on air supply and check for leakage. If leaks occur, repeat procedure.
6. To service lubricator, (see cutaway view)
 - A. Turn off air supply and depressurize the unit.
 - B. Unscrew threaded collar and remove the bowl and seat.
 - C. Remove the two (2) screws in the body holding the plastic insert. Remove insert, insert seal and o-ring from body.

- D. Clean all internal sealing surfaces and bowl assembly. (See polycarbonate bowl cleaning section.)
- E. Lubricate all seals and o-rings with grease found in the kit.
- F. Install bowl o-ring into body. NOTE: The kit contains both Compact and Standard bowl seals. Use the appropriate o-ring and discard the extra one.
- G. Sub-assemble insert, o-ring, seat, check ball and spring (under flapper, Standard only), flapper, baffle (Compact only) and mounting screws. NOTE: The flapper must be assembled so that the hole in the flapper lines up with the hole in the insert.
- H. Install insert and tighten the two (2) screws to 10 - 12 inch pounds of torque.
- I. Install bowl into body. Tighten Standard collar to 48 - 52 inch pounds of torque.
- J. Turn on air supply and check lubricator for leakage. If leakage occurs, DO NOT OPERATE - conduct repairs again.

SAFETY: Polycarbonate Bowls

CAUTION:

Polycarbonate bowls, being transparent and tough, are ideal for use with Filters and Lubricators. They are suitable for use in normal industrial environments, but should not be located in areas where they could be subjected to direct sunlight, an impact blow, nor temperatures outside of the rated range. As with most plastics, some chemicals can cause damage. Polycarbonate bowls should not be exposed to chlorinated hydrocarbons, ketones, esters and certain alcohols. They should not be used in air systems where compressors are lubricated with fire-resistant fluids such as phosphate ester and di-ester types.

Metal bowls are recommended where ambient and/or media conditions are not compatible with polycarbonate bowls. Metal bowls resist the action of most such solvents, but should not be used where strong acids or bases are present or in salt laden atmospheres. Consult the factory for specific recommendations where these conditions exist.

TO CLEAN POLYCARBONATE BOWLS USE MILD SOAP AND WATER ONLY! DO NOT use cleansing agents such as acetone, benzene, carbon tetrachloride, gasoline, toluene, etc., which are damaging to this plastic.

<u>MAINTENANCE SERVICE KITS</u>	<u>STANDARD 3/4"</u>
<u>Lubricator Repair Kit</u>	<u>601143</u>
<u>Drip Control and Fill Plug Kit</u>	<u>601142</u>

ITEM	FILTER	REGULATOR	LUBRICATOR
Relieving Kit		601138	
Poly Bowl Kit (No Drain)			601141
Push & Drain Kit (Poly Bowl)	601133		
Metal Bowl Guard	601134		601134
Drain Kit (Push-N-Drain)	601135		
40 Micron Element Kit	601136		
5 Micron Element Kit	601137		
Air Gauge (0 - 160 PSD)		601104	
Lubricator Sight Dome & Fill Kit			601142
Regulator Bonnet Assembly		601139	
Regulator Seat Insert Kit		601140	
Mist Lubricator Service Kit			601143

Rhino Tool Company
 PO Box 111, 620 Andrews Avenue
 Kewanee Illinois 61443 USA
 Phone: 309/853-5555
 Fax: 309/856-5905

@Copyright 2002 Rhino Tool Company
 Form 232 - 9/02
 Printed in USA